

INSTALLATION AND OPERATING INSTRUCTIONS FOR F20 SERIES HEAVY DUTY FLOW SWITCHES

**PLEASE READ THIS INSTALLATION SHEET CAREFULLY AND FULLY BEFORE
INSTALLING OR SERVICING THIS FLOW SWITCH**

INTRODUCTION

The F20 series flow switch is a versatile heavy-duty paddle flow switch suitable for detecting flow or no flow conditions in liquids flowing in pipes of any diameter from 20mm (3/4") upward.

This flow switch has several unique features.

- A) The complete electrical assembly can be removed from the switch by undoing and removing the locking screw in the split clamp on the side of the switch's electrical housing. With the locking screw removed the electrical housing can be pulled straight off the wet end of the switch. Removing the electrical housing allows the wet end of the switch to be unscrewed from pipework without disturbing the cable connection to the switch. This means the paddle of the switch can be changed, inspected or trimmed without the need to disturb the electrical connection to the switch. Always replace and tighten the locking screw after completing any work on the wet end of the switch.
- B) The F20 flow switch has a built in manual override. On the end of the switch body underneath the cable entry port is a spring loaded push button. Pressing this button actuates the switch, regardless of the state of flow. Pumping systems can be manually started by pressing this button and holding it in until flow is established. The override button can be used to test control circuits and wiring during commissioning, without the need for water in the pipework. The button is spring loaded so it can't be inadvertently left in the on position and only overrides the flow switch while it is pressed.

The F20 flow switch may have been supplied in one of several available configurations. The model number of the specific switch is located inside the lid of the electrical housing. The table below sets out the operating limitations of each model.

OPERATING LIMITATIONS

Switch Model	F20-S (All Poly Switch)	F20-SS (Stainless)	F20-B (Brass)	F20-D (Dieseline)
Maximum operating pressure (static or dynamic) at ambient temperature	18 Bars (260 psi)	200 Bars (2880 psi)	100 Bars (1440 psi)	100 Bars (1440 psi)
Minimum burst pressure at ambient temperature	45 Bars (650 psi)	500 Bars (7200 psi)	250 Bars (3600psi)	250 Bars (3600psi)
Maximum operating temperature (Liquid)	60°C See Note Below	80°C	80°C	50°C
Minimum operating temperature (Liquid)	-20°C	-20°C	-20°C	0°C
Ingress protection rating (Weatherproof rating)	IP67	IP67	IP67	IP67

Warning note: Maximum operating pressure of the Polypropylene F20-S must be linearly de-rated as operating temperature is increased so that at 60°C the maximum permissible operating pressure for the switch is not more than one Bar Absolute.

INSTALLATION

Select a location for the flow switch in a straight run of pipe, ideally with five pipe diameters of straight pipe either side of the switch. This will ensure a linear non turbulent flow acts against the paddle of the switch. Do not install the flow switch in any location likely to expose it to turbulence, such as close to valves, pumps or pipe bends. The idea is to install the switch in a location where there is a smooth flow of liquid past the paddle and to obtain a stable non-chattering response from the flow switch. The F20 flow switch can be mounted in either the suction or discharge pipe of a pump, the switch will work equally well in positive or negative pressure applications.

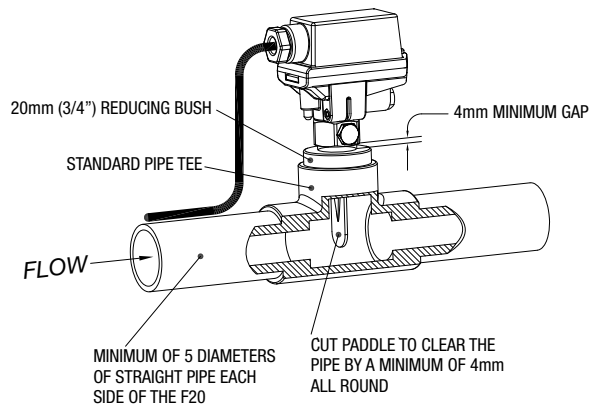

The F20 flow switch has an extra long paddle so it can be used in large diameter pipes. The paddle will require trimming if the flow switch is to be used in smaller diameter pipes. The paddle can be cut and shaped as required using tin snips or a hacksaw. Note, the paddle can be cut both in length and if required, in width. Many installers maintain a more stable flow response can be obtained by narrowing down the paddle and avoiding turbulence close to the walls of the pipe.

The F20 flow switch can be installed in any required orientation except on the under side of horizontal pipes.

Depending on the thread on the switch, a 20mm, 3/4" B.S.P. or 3/4" NPT threaded socket must be provided on the piping, to fit the flow switch. This may be a tapping saddle or a pipe tee fitted with a threaded reducing bush, or a socket welded directly to the pipe. Ensure that whatever fitting is used sufficient clearance is allowed for the free movement of the paddle. Normally a clearance to the full inside diameter of the 3/4" pipe thread will be required. The F20 flow switch can be installed in a 3/4" pipe socket attached to a short stand off pipe at 90° to the main pipe. This method of mounting increases the sensitivity of the switch to low flows due to the extra leverage against the tip of a longer paddle. If this mounting method is used make sure to leave extra clearance to allow for the full arc movement of the longer paddle.

Use thread tape or a suitable thread sealant and tighten the switch into the socket using the spanner flats provided on the switch body. Do not tighten the switch into its socket by twisting the electrical housing of the switch, as damage to the flow switch may result. Align the flow switch squarely to the axis of the pipe, with the direction of flow arrow on the side of the switch body parallel to the axis of the pipe and aligned in the direction of flow. The F20 will not function correctly unless alignment is correct.

When installing the flow switch in vertically aligned pipework, the sensitivity of the switch will be slightly increased. It will detect lower flows when flow is downward and the sensitivity will be slightly decreased when flow is upward. This is due to the effect of gravity on the dead weight of the paddle itself. This effect is more noticeable in larger pipes and low flows where long paddles may be used.

ELECTRICAL

All electrical work associated with this flow switch must be carried out by qualified persons only and must be in accordance with the relevant local codes.

The F20 flow switch houses a magnetically coupled high current high voltage single pole double throw microswitch that is suitable for general-purpose control circuit applications at any voltage up to 500VAC. The accompanying table gives the electrical rating of the switch, and the sketch below shows the switch's terminal designations.

The cable gland on the F20 flow switch is threaded M20 and will accept standard M20 conduit bushes in addition to flexible cable. When wiring an F20 flow switch ensure the lid and cable gland are securely tightened and in fully exposed locations use secondary precautions such as cable drip loops to make sure no water can enter the switch housing.

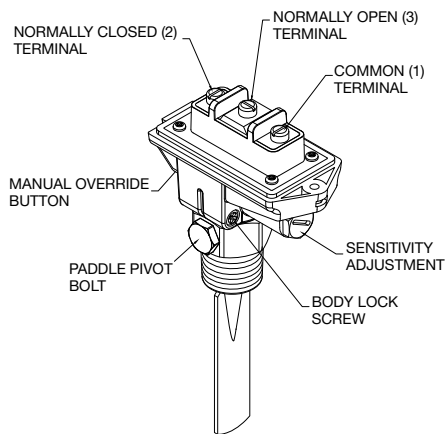

PADDLE TRIMMING AND FLOW SENSITIVITY

There are two methods of setting the sensitivity of the F20 flow switch. By far the most effective method is by the correct trimming of the paddle. For fine tuning, a sensitivity adjustment screw is provided, as shown in the accompanying drawing. As supplied by the factory the sensitivity screw is wound fully in and is set to least sensitivity. The adjusting screw can be wound out, and the sensitivity slightly increased. The maximum effect is achieved with the screw wound out to a point where the screw head is 4mm in from the face of the switch body.

By far the best way to set the F20 flow switch is to make a judgment on the likely flow rate in the pipe and to trim the paddle accordingly. If the flow is going to be high then trim the paddle fairly short and if you know the flow rate will be low then leave the paddle as long as possible. If the flow rate is unknown then generally trimming the paddle to half way across the pipe will achieve a satisfactory compromise and will work well. Trimming the paddle is a compromise between sensitivity to the duty flow and stress on the intruding paddle. Fluid flow generates force and a certain minimum amount of force is required by the flow switch in order to function. Excessive force however can bend or break paddles.

The exact flow rates required to actuate the F20 will depend on many variables such as turbulence, liquid viscosity and the exact area of the paddle face exposed to the flow.

For an accurate estimation of the switching point for any given paddle size, an online flow calculator is available at <http://www.kelco.com.au>

ELECTRICAL DATA

The F26-S flow switch is suitable for general control circuit applications up to 500VAC. In addition, the switch can be used to directly control small single-phase 240VAC pump motors up to 0.360kW maximum.

Rated Voltage	NON INDUCTIVE LOADS			INDUCTIVE LOADS		
	Resistive Load		Lamp Load	Inductive Load		Motor Load
	NC	NO	NC	NO	NC	NO
125 VAC	15A	3A	1.5A	15A	5A	2.5A
250 VAC	15A	2.5A	1.25A	15A	3A	1.5A
500 VAC	10A	1.5A	0.75A	6A	1.5A	0.75A
8 VDC	15A	3A	1.5A	15A	5A	2.5A
14 VDC	15A	3A	1.5A	10A	5A	2.5A
30 VDC	6A	3A	1.5A	5A	5A	2.5A
125 VDC	0.5A	0.5A	0.5A	0.05A	0.05A	0.05A
250 VDC	0.25A	0.25A	0.25A	0.03A	0.03A	0.03A

MAINTENANCE

If the F20 flow switch is correctly installed and if the process liquid is compatible with the materials of construction of the switch then a very long maintenance free service life can be expected. Factors that may contribute to early failure of the F20 flow switch include excess temperature, excessive pressure or electrical loads in excess of the switch's rating. Should service be required, an exploded view of the flow switch is included to show the main components and how they fit together. The F20 is a very simple switch to service, and all components are available as spare parts.

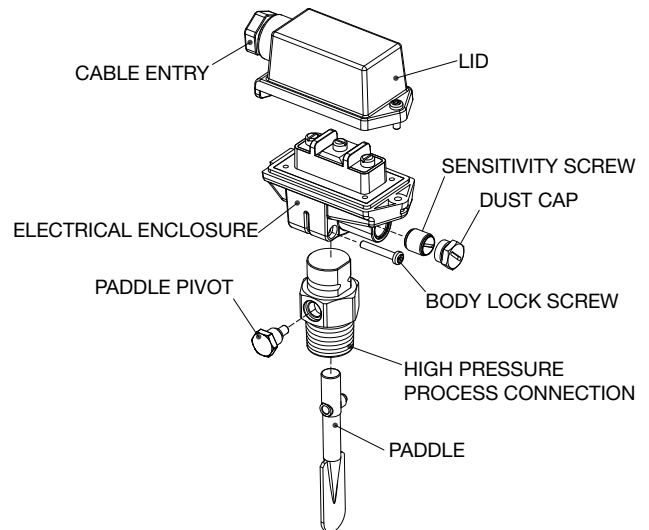

HAZARDOUS APPLICATIONS

The F20 flow switch can be used in hazardous areas. The flow switch is classed as a simple device and does not contain components capable of storing or producing an electric charge. As a simple device the F20 can be used in hazardous applications provided an intrinsically safe barrier, a zener barrier, isolates it.

MADE IN AUSTRALIA BY

KELCO Engineering Pty Ltd

ABN 20 002 834 844

Head Office and Factory: 9/9 Powells Road BROOKVALE 2100 AUSTRALIA

Postal Address: PO Box 496 BROOKVALE NSW 2100

Phone: +61 2 99056425 Fax: +61 2 99056420

Email: sales@kelco.com.au Web www.kelco.com.au

PLEASE NOTE: Kelco Engineering Pty Ltd reserves the right to change the specification of this product without notice. Kelco Engineering Pty Ltd accepts no liability for personal injury or economic loss as a consequence of the use of this product. All rights reserved copyright Kelco Engineering Pty Ltd © 2010