

F40 DIGITAL PUMP CONTROLLER

FOR ALL PIPE SIZES 25mm (1") AND LARGER



APPLICATIONS

- DOMESTIC WATER SUPPLY
- INDUSTRIAL PUMP CONTROL
- CONTROL OF TRANSFER PUMPS
- IRRIGATION PUMP CONTROL
- PRESSURE BOOSTING PUMPS
- WATER TREATMENT SYSTEMS
- WASHDOWN CONTROL
- POOL & SPA PUMPS
- BORE PUMP CONTROL

FEATURES

- ELIMINATES PRESSURE TANKS AND SWITCHES
- NO METAL PARTS IN CONTACT WITH WATER
- STARTS ON PRESSURE STOPS ON FLOW
- SUITS ALL PIPE SIZES 25mm (1") & LARGER
- HIGHLY ADAPTABLE & ADJUSTABLE
- AUTO RESTART AFTER RUNNING DRY
- DIRECTLY CONTROL PUMPS TO 3.75kW
- IGNORES MINOR FLOW FLUCTUATIONS
- INDICATOR LIGHTS FOR ALL FUNCTIONS
- SUITABLE FOR USE IN SEAWATER
- TOUGH RELIABLE CONSTRUCTION
- 20 BAR (300 psi) PRESSURE RATING
- WEATHERPROOF HOUSING IP67
- SIMPLE PLUG IN INSTALLATION

INTRODUCTION

The F40 Digital Pump Controller is a powerful self-contained microcomputer that controls and protects a pump under its command. The F40 provides a seamless environment for the pump and gives the end user all the advantages of constant flow and at the same time protects the pump against damage from being run dry. Constant flow means a smooth supply free from the pressure fluctuations that plague conventional pressure controlled pumps.

THE BASIC PROBLEM

Pressure systems cycle between low and high pressure. Not because this gives the user any advantage but simply because a pressure differential is required to operate the pressure switch that normally controls such systems. The user sees the effect as annoying pressure fluctuations at the tap. If run dry for any reason, such a pressure system will run continuously and generally sustain serious damage because it has no means to sense the lack of water and shut down.

THE F40 SOLUTION

The F40 Digital Pump Controller monitors both flow and pressure and only allows the pump to run if water is present. In a typical application the pump will start when there is a demand for flow or when the pressure falls. When demand ceases the controller continues to run the pump for a settable time that is sufficient to re-pressurise the system. The pump will then automatically shut down. Such a system allows the selection of a pump that has an essentially flat pressure and flow curve and delivers a steady constant pressure over widely varying flows. An air cell is not needed in the system but can be included to reduce the frequency of pump starts. With the F40 controller the start-up pressure is set to start the pump at a pressure only marginally higher than the system's static pressure. If the demand is too low to actuate the F40's flow sensor, or if for any reason the pressure falls, the F40's built in pressure sensor will detect the pressure fall, automatically run the pump, re-pressurise the system, then shut down the pump and go back to monitoring the whole system.

DRY RUN PROTECTION

A pump under the control of an F40 will start if the pressure drops, or on flow if a tap is turned on. If the system runs out of water the F40 senses the loss of flow and the lack of pressure and stops the pump. A red warning light on the F40 then flashes rapidly to indicate there is a problem. The F40 can be set to simply remain in alarm mode until attended to, or to wait for a settable time and then attempt to restart the whole system.

AUTOMATIC RESTART FEATURE

The digitally controlled restart feature on the F40 is ideal for pumping from low yield bores. Under the control of an F40 a bore pump can be automatically cycled. It can be pumped until dry and then left for a settable time for the standing water level to recover. The whole process can then be repeated endlessly. Using this method a low yield bore can be pumped to its maximum capacity. The F40 can be set to automatically restart the pump from 1 minute to 48 hours after being run dry.

CONSTRUCTION

The F40 digital pump controller is made from high compliance thermoplastic and has no metal parts in contact with water. It operates magnetically through a seal-less coupling system. It is ideal for use in potable drinking water, aggressive bore water, seawater and a huge variety of chemical solutions.



AUSTRALIAN MADE

TECHNICAL DATA

DIMENSIONS

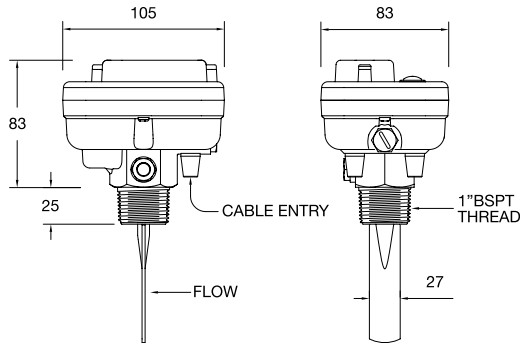

ORDERING

The F40 Digital Pump Controller is available in a number of configurations to suit specific applications. For directly controlling pumps up to 2.4kW (3HP) It can be supplied as 'Plug & Play' with 10Amp leads and fitted with a plug and socket. For large fixed installations It can also be supplied in a heavy duty form fitted with 2 metre long 15A cables, or fitted with a single 2 metre long cable that has either 4 or 5 cores for either direct control of pump motors to 2.4kW (3HP) (4 core version), or with 5 core cable for use in single and 3-phase control circuit applications. In addition there is a universal low voltage AC/DC model available. The part numbering system below sets out how to order a specific configuration.

The standard F40 has a startup pressure range of 0 to 10 Bars. High start up pressure models are available that have a start up pressure range of 0 to 20 Bars (0 to 300 psi). To order controllers with this option simply add "HP" to the end of the part number.

F40 - 240 - S - 5

SUPPLY VOLTAGE
240 = 220 TO 240VAC
24 = 24V AC or DC

CABLE CORES
4 = 4 CORE 10Amp CABLE
5 = 5 CORE 6Amp CABLE

CABLE

NO LETTER = 10Amp PLUG & PLAY
HD = HEAVY DUTY 15Amp CABLES 2 X 2M LONG
S = SINGLE CABLE 2M LONG WITH 4 or 5 CORES

Please Note: The universal 24V AC/DC model is only available in F40-24-S-5 configuration, that is, with a single 5-core cable for control circuit applications only.

OPERATING ENVIRONMENT

Supply F40-240	220 to 250VAC 50Hz Single Phase
Supply F40-24	12 to 28 Volts AC or DC at 80mA Max.
Ambient Temperature Range	1°C to 50°C
Liquid Temperature Range	1°C to 60°C
Ingress Protection Rating	IP67

WARRANTY

The Kelco F40 Digital Pump Controller is protected by a 12 months return to base warranty. Full details of our warranty can be downloaded from: - <http://www.kelco.com.au/menu/information/warranty-statement/>

OPERATING RANGE

Start-up Timer	Adjustable from 1sec. to 3 minutes in 15 steps
Run-on Timer	Adjustable from 1 sec. to 5 minutes in 15 steps
Restart Timer	Adjustable from 1 minute to 48 hours in 15 steps
Pump Start Pressure Range	0 to 10 Bars (0 to 150 psi) in 16 steps, See note below
Maximum Starting Pressure	1000kPa (150 psi)
Minimum Starting Pressure	50kPa (7 psi)
Recommended Pipe Sizes	25mm (1") or larger. (There is no upper limit)
Maximum Switched Load F40-240	250VAC 50Hz 2.4kW (Motors up to 3HP)
Maximum Switched Load F40-240-HD	250VAC 50Hz 3.75kW (Motors up to 5HP)
Maximum Switched Load F40-240-S-4	250VAC 50Hz 2.4kW (Motors up to 3HP)
Maximum Switched Load F40-240-S-5	250VAC 50Hz 6Amps Non Inductive
Maximum Switched Load F40-24-S-5	250VAC 50Hz 6Amps Non Inductive
Operating Pressure Range, Static or Dynamic	0 to 20 Bars (0 to 300psi) See Note Below
Burst Pressure	50 Bars (750 psi)

NOTE: A high starting pressure model is available with a start up range of 0 to 20 Bars (0 to 300 psi), add "HP" to the part number for this option.

NOTE: The F40 pump controller must NOT be used in hot water applications (>60°C). The F40 pump controller is rated to withstand water pressure to 20 Bars (300 psi) and must not be used in applications where the static or dynamic pressure exceeds this rating.

TYPICAL PUMP INSTALLATION

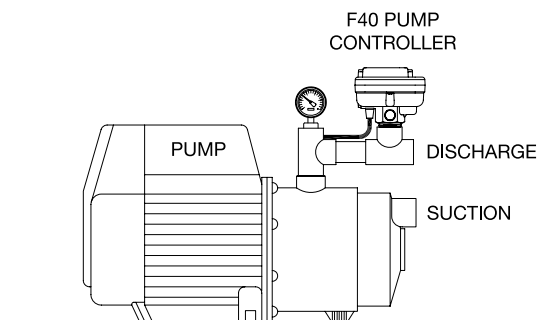

SPARE PARTS

Spare Paddles are available for the F40 Digital Pump Controller.

STANDARDS

The F40 Digital Pump Controller is certified to Australian Standards: -
AS60529-2004
AS61010.1: 2003
AS/NZS CISPR 14.1:2003

MADE IN AUSTRALIA BY

KELCO Engineering Pty Ltd

ABN 20 002 834 844

Head Office and Factory: 9/9 Powells Road BROOKVALE 2100 AUSTRALIA

Postal Address: PO Box 496 BROOKVALE NSW 2100

Phone: +61 2 99056425 Fax: +61 2 99056420

Email: sales@kelco.com.au Web: www.kelco.com.au

PLEASE NOTE: The Kelco F40 Digital Pump Controller is the subject of Australian and International patent and trademark applications.

Kelco Engineering Pty Ltd reserves the right to change the specification of this product without notice. Kelco Engineering Pty Ltd accepts no liability for personal injury or economic loss as a consequence of the use of this product. All rights reserved copyright Kelco Engineering Pty Ltd © 2010