

F50 ADVANCED PUMP CONTROLLER



The F50 advanced pump controller is a pump control computer that learns from its environment and adapts itself to the pressure and flow conditions it finds in a pump system. It is able to control a pump within settable pressure limits and yet operate on flow. It gives the user constant pressure at the tap and also protects the pump from running dry.

INTRODUCTION

Basic pump controllers that integrate flow and pressure normally start on pressure or flow and stop when flow stops. More advanced controllers such as our F40 series provide an adjustable run-on that allows time for pressure to rise in the system before the pump is shut down. The F50 advanced pump controller takes pump control to the next level. In addition to the usual start on pressure stop on flow system used in most pump controllers, it adds the ability to set an upper pressure limit on the system. This feature means the system pressure can't exceed safe pressure limits. It means that low class pipe can be used in a fully automatic pump system without any risk of bursting the pipework.

Unlike a basic pressure switch operated system that also sets an upper pressure limit, the F50 learns from its environment and remembers what the upper pressure limit is. In normal operation the F50 lets the pump start and stop instantly on flow. If the system pressure creeps up and eventually reaches the cutout pressure, the F50 automatically reverts to pressure start mode and will not allow the pump to start regardless of flow demand until the pressure has fallen to the startup pressure. This system gives the user the best features of an F40 pump controller with the added advantage of an adjustable high-pressure limit on the system.

DRY RUN PROTECTION

A pump under the control of an F50 will start if the pressure drops, or on flow if the tap is turned on. If the system runs out of water the F50 senses the loss of flow and the lack of pressure and stops the pump. If set to auto restart, it then waits for 15 minutes and then attempts to restart the pump.

APPLICATIONS

- DOMESTIC WATER SUPPLY
- INDUSTRIAL PUMP CONTROL
- CONTROL OF TRANSFER PUMPS
- IRRIGATION PUMP CONTROL
- PRESSURE BOOSTING PUMPS
- WATER TREATMENT SYSTEMS
- WASH DOWN CONTROL
- POOL & SPA CONTROL

FEATURES

- HIGH PRESSURE CUTOUT
- STARTS ON PRESSURE OR FLOW
- RUNS ON FLOW
- STOPS ON PRESSURE OR TIME
- 10 & 20 BAR VERSIONS AVAILABLE
- NO METAL PARTS IN CONTACT WITH WATER
- SUITS ALL PIPE SIZES 25mm (1") & LARGER
- HIGHLY ADAPTABLE AND ADJUSTABLE
- DIRECTLY CONTROL PUMPS TO 3.75kW
- INDICATOR LIGHTS FOR ALL FUNCTIONS
- SUITABLE FOR USE IN SEA WATER
- WEATHERPROOF HOUSING IP67
- PLUG AND PLAY MODEL AVAILABLE

HIGH PRESSURE CUTOUT

The F50 Pump Controller has an adjustable high-pressure limit. The upper pressure limit can be set by simply adjusting a dial on the F50's control panel. The high-pressure limit ensures the system pressure can't exceed an acceptable level. It means a high pressure pump can be effectively controlled and held within safe working limits.

AUTOMATIC RESTART FEATURE

The automatic restart feature on the F50 can be switched on or off. It is ideal for pumping from low yield bores. Under the control of an F50 a bore pump can be automatically cycled. It can be pumped until dry and then left for the standing water level to recover. The whole process can then be repeated endlessly. Using this method a low yield bore can be pumped to its maximum capacity. The F50 can be set to automatically restart the pump 15 minutes after being run dry. If it fails to find water after the second attempt, it waits a further 6 hours, tries again and if no water is found, repeats the process after waiting a further 12 hours. After the fourth attempt, if the system is still running dry the F50 reverts to lock out alarm mode and flashes its red warning lights rapidly to indicate there is a problem. The pump will not then attempt to restart until it is attended to.

AUTOMATIC RUN-ON FEATURE

The F50 features a 20 second auto resetting run-on timer that can be switched on or off. The resetting run-on resets its internal timer every time the controller senses an interruption to flow. Its use enables bore pumps, jet pumps and self priming pumps to tolerate partial dry run and to cope with gas or entrained air in the system's pipework. The F50 also has 15 manual run-on settings that can be used to set how long a pump runs on after flow stops. These settings provide the user with enormous flexibility in precisely pressurizing air cells and system pipework.

TECHNICAL INFORMATION

FLEXIBLE AUTO TERMINATING START TIMER

The F50 Pump Controller has a highly adjustable auto terminating start timer that overrides the initial lack of flow in the system and allows the pump to start. As soon as the F50 senses flow the timer terminates its run regardless of what time period it is set to. For domestic pressure systems the start timer may only run for a second or two before flow is established. In deep well bore pump applications where a submersible pump is fitted with a self draining riser it may take several minutes for flow to reach the surface. For such applications the F50 can be set to keep the pump running for up to 3 minutes to allow water to reach ground level.

CONSTRUCTION

The F50 Pump Controller is made from high compliance glass reinforced thermoplastic and has no metal parts in contact with water. It operates magnetically through a seal-less coupling system. It is ideal for use in potable drinking water, aggressive borewater, seawater and a huge variety of chemical solutions.

ORDERING

The F50 Pump Controller is available in a number of configurations to suit specific applications. For directly controlling pumps up to 2.4kW (3HP) it can be supplied as 'Plug & Play' with 10Amp leads and fitted with a plug and socket. For large fixed installations it can also be supplied in a heavy duty form fitted with 2 metre long 15A cables, or fitted with a single 2 metre long cable that has either 4 or 5 cores for either direct control of pump motors to 2.4kW (3HP) (4 core version), or with 5 core cable for use in single and 3-phase control circuit applications. In addition there is a universal low voltage AC/DC model available. The part numbering system below sets out how to order a specific configuration.

ORDER CODE

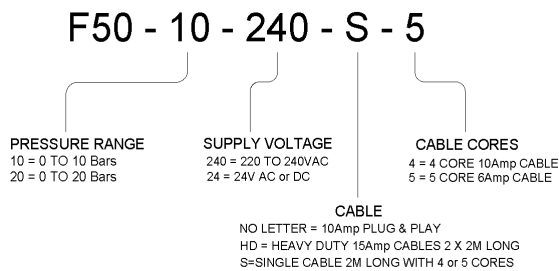

OPERATING ENVIRONMENT

Supply F50-240	220 to 250VAC 50Hz
Supply F50-24	12 to 28 Volts AC or DC, 100mA
Ambient Temperature Range	1°C to 50°C
Liquid Temperature Range	1°C to 60°C See note below
Ingress Protection Rating	IP67

OPERATING RANGE

Start-up Timer	Adjustable from 1sec. to 3 minutes in 15 steps
Run-on Timer	Adjustable from 1 sec. to 5 minutes in 15 steps
Automatic Restart Timer	Automatic 4 attempts to Start after 15 mins, 1 hr, 6 hrs and 12 hrs.
Pump Start Pressure Range (10 Bar model)	0.5 to 8 Bars in steps of 0.5 Bars
Pump Start Pressure Range (20 Bar model)	1 to 16 Bars in steps of 1 Bar
Pump Stop Pressure Range (10 Bar model)	2.5 to 10 Bars in steps of 0.5 Bars
Pump Stop Pressure Range (20 Bar model)	5 to 20 Bars in steps of 1 Bar
Recommended Pipe Sizes	25mm (1") or larger. (There is no upper limit)
Maximum Switched Load F50-240	250VAC 50Hz 2.4kW (Motors up to 3HP)
Maximum Switched Load F50-240HD	250VAC 50Hz 3.75kW (Motors up to 5HP)
Maximum Switched Load F50-240-S-4	250VAC 50Hz 2.4kW (Motors up to 3HP)
Maximum Switched Load F50-240-S-5	250VAC 50Hz 6Amps Non Inductive
Maximum Switched Load F50-24-S-5	250VAC 50Hz 6Amps Non Inductive
Operating Pressure Range, Static or Dynamic, all models	0 to 20 Bars (0 to 300psi) See Note Below

DIMENSIONS

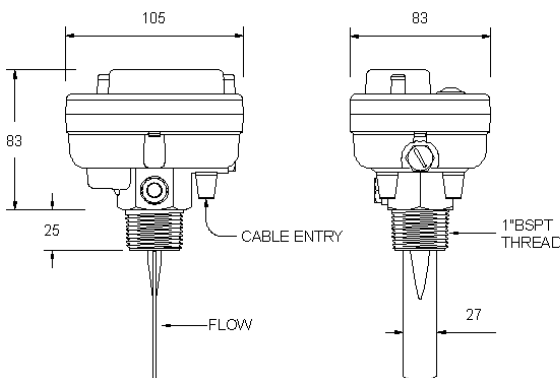

Please Note: The universal 24V AC/DC model is only available in F50-24-S-5 configuration, that is, with a single 5-core cable for control circuit applications only.

MADE IN AUSTRALIA BY

KELCO Engineering Pty Ltd

ABN 20 002 834 844

Head Office and Factory: 9/9 Powells Road BROOKVALE 2100 AUSTRALIA

Postal Address: PO Box 496 BROOKVALE NSW 2100

Phone: +61 2 9905 6425 Fax: +61 2 9905 6420

Email: sales@kelco.com.au Web: www.kelco.com.au

PLEASE NOTE: Kelco Engineering Pty Ltd reserves the right to change the specification of this product without notice. Kelco Engineering Pty Ltd accepts no liability for personal injury or economic loss as a consequence of the use of this product. All rights reserved copyright Kelco Engineering Pty Ltd © 2010